

The Truth of the Matter

It has become very difficult for those selecting surge protection to choose the most reliable, yet cost-effective protection devices in the marketplace.

Making the right selection should be painless, and with a sufficient knowledge and some common sense, it can be.

The following are a collection of topics relating to transient voltage suppression presented in format that is concise and accurate.

MCG
SURGE
PROTECTION

Contents

Page

Front Page	1
Contents	2
Q & A on Surge Protection	3
Lightning & Transients Considerations	
Anatomy of a Lightning Strike	5
Economic Justification for Surge Protection	6
Surge Protection Overview	
System Protection Recommendations	7
Suggested “Product Comparison Sheet”	8
Major Issues That You Need to Consider	
Peak Current Capability	9
Protection Guidelines -CBEMA Standards	10
“Let Through” Voltage - Can It Be Reduced?	11
“Let Through” Voltage - Wire Size Considerations	12
Micro-Z Concept - For Better Performance	13
Voltage Drops Along Power Cabling	14
High AC Line Voltage - requires several strategies	15
Other Important Issues	
Fuse and Thermal Disconnect Considerations	16
Redundancy - True vs. False Redundancy	17
Modular Design Considerations & Problems	18
Monitoring & Diagnostics	19
Life Expectancy	20
Environmental Factors	20
Enclosures - NEMA	20
Installation Notes	
Installation Q & A	21
Wiring Diagrams - Phase Connections	22
Safety Disconnect Switch Considerations	23
Ground - The Single Point Concept	23
Promoted Ideas of Questionable Merit	
Sine Wave Tracking & EMI/RFI Filtering	24
Hybrid Protection Circuitry	25
Test Equipment - Useful or Illusionary	26
Observing the Passing Scene	
Open Technology - Why the Secrecy?	27
Advertising - Exotic Uses of the English Language	28
Standards	
Standards - Industry and Safety	29
ANSI C62.41-1991 Waveforms	30
Glossary of Technical Terms	31
Warranty	31
Index	32

Q & A:

Surge Protection

Why surge protection?

The tremendous proliferation in the use of sensitive electronic equipment, sensitive by virtue of the circuit density - (microchips having literally millions of transistors on a single chip) - predisposes any discussion on the NEED for surge protection.

The increasing vulnerable circuitry exists in an extremely hostile environment. It is subjected daily to potentially disruptive and destructive surges from industrial accidents, utility network switching and, of course, lightning strikes. The most logical and cost effective defense is surge protection.

To best serve your needs, define what you want to accomplish:

- For blackouts, brownouts and dips, choose a UPS.
- To protect a UPS, choose a surge protector.
- For upset or damage by surges, choose a surge protector.
- For I/O port damage, choose a data line protector.

What is the proper protection size?

A surge entering a facility will dissipate by subdividing throughout the building's power distribution system.

The capability of a surge suppressor is determined by its intended location. At the point of entry the energy contained in a surge is at maximum. Fanning out on its journey through the system, it will offer less magnitude to each branch panel encountered. Finally, the least amount of damaging surge current will be experienced by the local panels and outlets deep in the system.

MCG protectors range from point-of-entry service panel protectors to low-profile protection for internal equipment protection.

Why surge protection by MCG?

MCG Electronics has specialized in the design, development and manufacture of high quality lightning, surge and tran-

sient overvoltage protection devices since 1967. MCG pioneered many of the innovations that are commonplace today such as modularity, redundancy, very low impedance "Micro-Z" wiring, extensive local diagnostics for ease of servicing, event monitoring, audible alarm, etc.

A really good surge protector is one that works well and lasts a long time. The SPD (Surge Protection Device) should have redundant protection, be modular design, reasonably priced and come with before and after sales support.

How do I choose a surge protector?

The specifier and user of an SPD has the unenviable task of sifting through the many and widely varied performance data from surge suppressor manufacturers. One would be prudent to question unrealistic or non-real-world claims. Specification data should be documented and further substantiated with evidence such as scope traces verifying testing against defined waveforms. Disclosure of technology should be insisted upon and bashful manufacturers considered suspect.

How does an SPD work?

Suppression of transient surges and overvoltages is achieved by the use of metal oxide varistors (MOV), installed in shunt with the AC power lines. The MOV under normal conditions is a high resistance element rendering it virtually invisible on the line. Any transient exceeding the threshold (typically 115% of nominal) will cause the MOV's resistance to drop rapidly (in nanoseconds) to provide a very desirable path for the excess surge current. An effective SPD will divert damaging transients harmlessly away from the sensitive load with nanosecond speed.

When an event occurs and suppression takes place a remnant or let-through voltage will be what the protected equipment will see. Obviously, it is desirable to limit this voltage to a low level. A major factor in achieving this is reducing impedance to the surge. This is where MCG shines.

What exactly is meant by Micro-Z?

Any impedance between the power line and ground will inhibit the diversion of transient current to ground. Two conditions are necessary for a surge diversion to be effective:

1. Keep the surge impedance of the leads connecting the SPD to the AC power line low by making the wiring short

(continued from previous page)

and direct. Dress all leads tightly together and tape the wire over the full length of the wire run. MCG's Micro-Z cabling has 50% less drop than well constructed conventional cabling.

2. The internal surge impedance of the SPD must be reduced by careful attention to design. Patented MCG Micro-Z circuitry has been designed to create a low impedance surge path through the protection device which significantly reduces the voltage drop across the internal SPD wiring.

Combining the benefits of a low internal SPD impedance with a low impedance connection to the AC power line permits MCG to use higher voltage MOVs without a sacrifice in the surge suppression performance. The additional headroom above the nominal +/-10% power line voltage translates to much more reliable operation and longer SPD life.

Response time - how fast should it be?

Claims are made of less than one nanosecond response (and occasionally) less than one picosecond to clamp a transient. This should prompt some thought. A nanosecond is one billionth (with a 'b') of a second. WOW! How does one physically measure this speed to verify the claim? A glance at published literature released by MOV manufacturers shows these numbers, but further reading will disclose they are based on the MOV element operating in lead-less, coaxial environment. NOT REAL WORLD. It is only common sense that the MOV placed in a SPD must have leads to the power line and the resultant inductance makes the response time claims unrealistic. Organizations such as NEMA and Underwriters Laboratories have chosen to ignore this specification completely since MOVs have response times 100 to 1000 times faster than any transient they are likely to encounter.

What is the difference between Threshold Voltage and Clamp Voltage?

Threshold Voltage is the point at which an SPD conducts when 1ma of current is being delivered to the input. By itself this is incomplete as a performance criterion. Clamp is the voltage measured, with an oscilloscope, at the SPD terminals when standard test waveforms, such as defined by ANSI/IEEE C62.41-1991, are applied.

Underwriters Laboratories Standard UL 1449 establishes suppression ranges for comparing SPD's. Hardwired SPD units are tested at 6000 Volts, 3000 Amps (8/20µs waveform) and the SVR voltage is measured. As an example, an established UL range is 400 Volts. If test results for SPD were 340 Volts and another at 390 Volts, UL would

classify both as 400 Volt units, keeping in mind that the UL rating is a range. The "actual" suppression levels as well should be noted when comparing SPD's. In a critical application, the 50 Volt difference in the above example could be significant.

Energy Absorption

A metal oxide varistor will divert, absorb and dissipate the energy of a transient. It follows that this activity should be measured in units of energy (joules). Joules, as a measure of SPD performance, can be useful when comparing units employing MOV technology. More joules generally translates to a longer design life. However, a manufacturer should substantiate the published data. In addition, any joule rating must be accompanied by a waveform.

If a surge protector has a rating of 4000 joules (8/20µs), and another has a rating of 2000 joules (8/20µs), then the 4000 joule protector has a life expectancy 10 times greater than that of the second protector! Joules matter!

What does "Surge Current (8/20µs) really mean on an MCG data sheet?

These are life ratings. To illustrate, let's take the bottom rating of 10,000 impulses at a 5000A level. This indicates that the SPD can divert a transient of 5000 Amps, ten thousand times. This translates to suppressing a 5000 Amp transient every single day (holidays included) for 27.4 years. Not bad! What is likelihood of that occurring? Very unlikely! Consequently the SPD's life will be very long.

What is meant by Modes of Protection?

Modes of protection are MOV's surge elements connected from line to neutral, line to line, line to ground, and neutral to ground. For a wye system, this is 3-line to neutral, 3-line to ground, and 1-line to neutral, or 7 modes of protection.

Tracking the sine wave - real or myth?

Both, actually.

The purpose is to eliminate electrical "noise" and this is usually accomplished by adding capacitors to the protection circuitry. Since electrical noise generally is local in origin (copiers, fluorescent lights, vacuums, etc.) the real place to effectively solve this problem is at the equipment level. Protecting against noise at the building point of entry (before the noise) would appear to be something of a myth.

Anatomy of a Lightning Strike

*What You Can Expect**

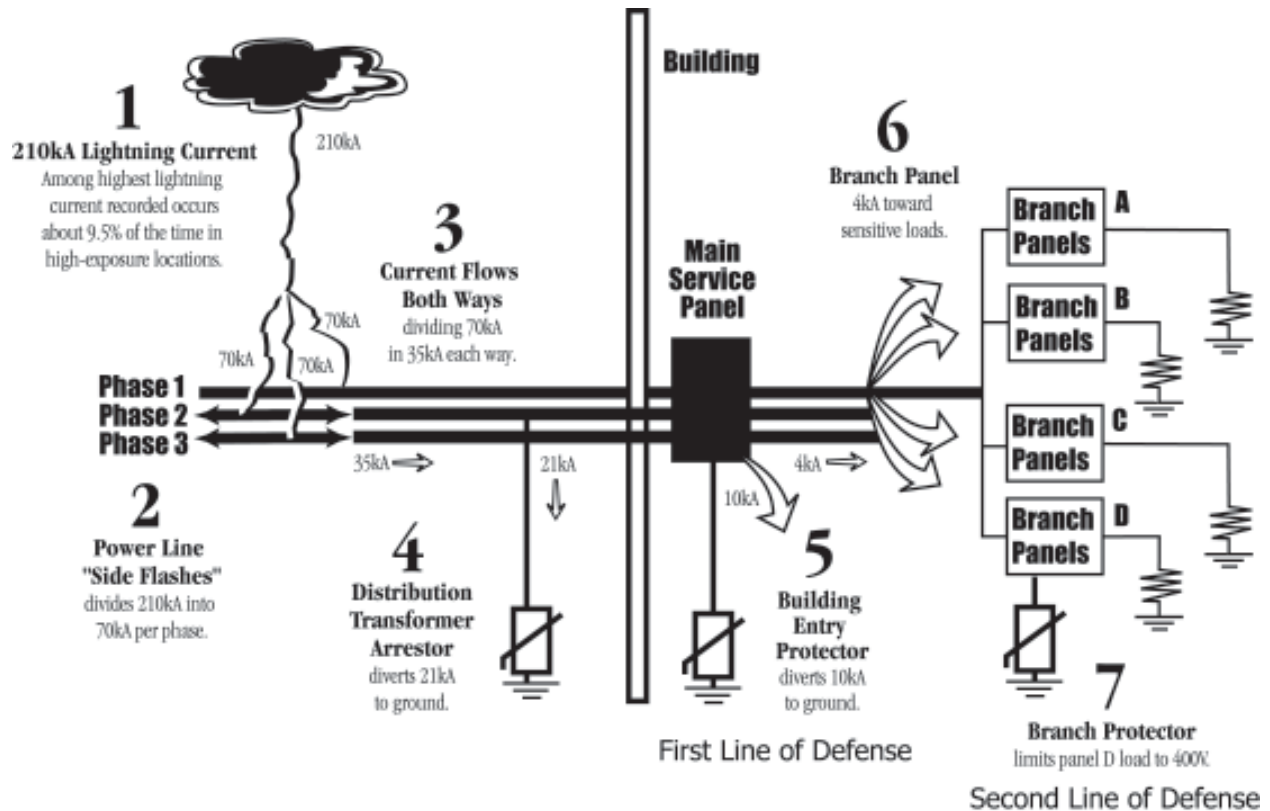

Your First Line of Defense - Building Entry Protection

One of the largest lightning transient currents recorded was 210kA with a duration in the tens of nanoseconds. By far, the greatest threat to sensitive equipment is from lightning strikes to overhead AC power lines which then couple the transient into your facility.

Your Second Line of Defense - Mid-Building Protection

Other very common sources of transient voltage spikes occur deep within a building and are caused by elevators, copiers, air conditioners, arc-welders etc. A suitably sized surge protector located at the branch panel will very effectively suppress locally generated transients. Any transient voltages arriving at a protected service panel will be limited to safe voltage levels.

**Surge Protection: Where and how much? - Dion Neri/MCG Electronics in EC&M, Mar. 1997, p.58*

Economic Justification for Surge Protection

Surge protectors come in different sizes.

Building entry surge protectors must provide a very substantial current diverting capability, whereas equipment deep within a building can be fitted with a much smaller protector to deal with residual lightning effects and locally generated transients.

A direct lightning strike can have surge currents up to 200kA.

These very high amplitude lightning transient current impulses are, fortunately, relatively few in number. These possible - but somewhat improbable events - should be taken seriously if a site has a history of direct strikes, nearby strikes to tall towers, strikes to industrial smoke stacks or strikes in the parking lot. These situations require a very substantial surge protection device capable of quickly and reliably diverting very large surge currents safely at the building entry point.

Fortunately, most lightning strikes are of a more moderate size.

However, they occur much more frequently, with surge currents of 10kA to 50kA and not uncommonly 100kA in amplitude. It has been estimated that lightning strikes the lower 48 Unites States at a frequency of 9 to 20 million strikes per year.

Another factor to consider is the economic costs associated with damaged or upset equipment and the loss of production capability and worker productivity. These unexpected costs in a critical facility, such as banks, airports, manufacturing plants, office buildings etc., would be many times the cost of the largest surge protectors. A heavy duty surge protector, costing \$3650, using a 10 year life calculation (actual life = 20+ years), will provide superb 24 hour surge protection at a cost \$1.00 /day.

Smaller sized surge protectors can be employed deeper within the building at considerably lower protection cost per day.

Can your company afford to be without the assurance that a good surge protector can provide?

System Protection Recommendations

This chart shows a typical power distribution system within a building and suggests the proper size of protectors to use throughout.

The most severe surges (lightning, utility switching, etc.) are most likely to be encountered at the building entry or distribution panel.

Based on your site's lightning probability, the kVA rating of the distribution transformer serving the building, and the financial risk associated with downtime will determine the proper surge protection recommendation. Consult MCG for engineering evaluation.

In the mid-building area, additional transients are typically caused by the cycling on and off, or start-up and shut down of large inductive loads (i.e., elevators and air conditioners) as well as fuse or circuit breaker operations. A mid-sized (100 to 150kA), plug-in, pluck-out modular surge protector at the branch panel is a good choice.

At the local service panel, many of the surges result from the operation of office equipment (i.e., copy machines) fluorescent lighting and air conditioners. A smaller protector in the 80kA or 40kA class is best suited.

For OEM applications, use an in-line AC surge protector rated at 10kA that includes filter network within.

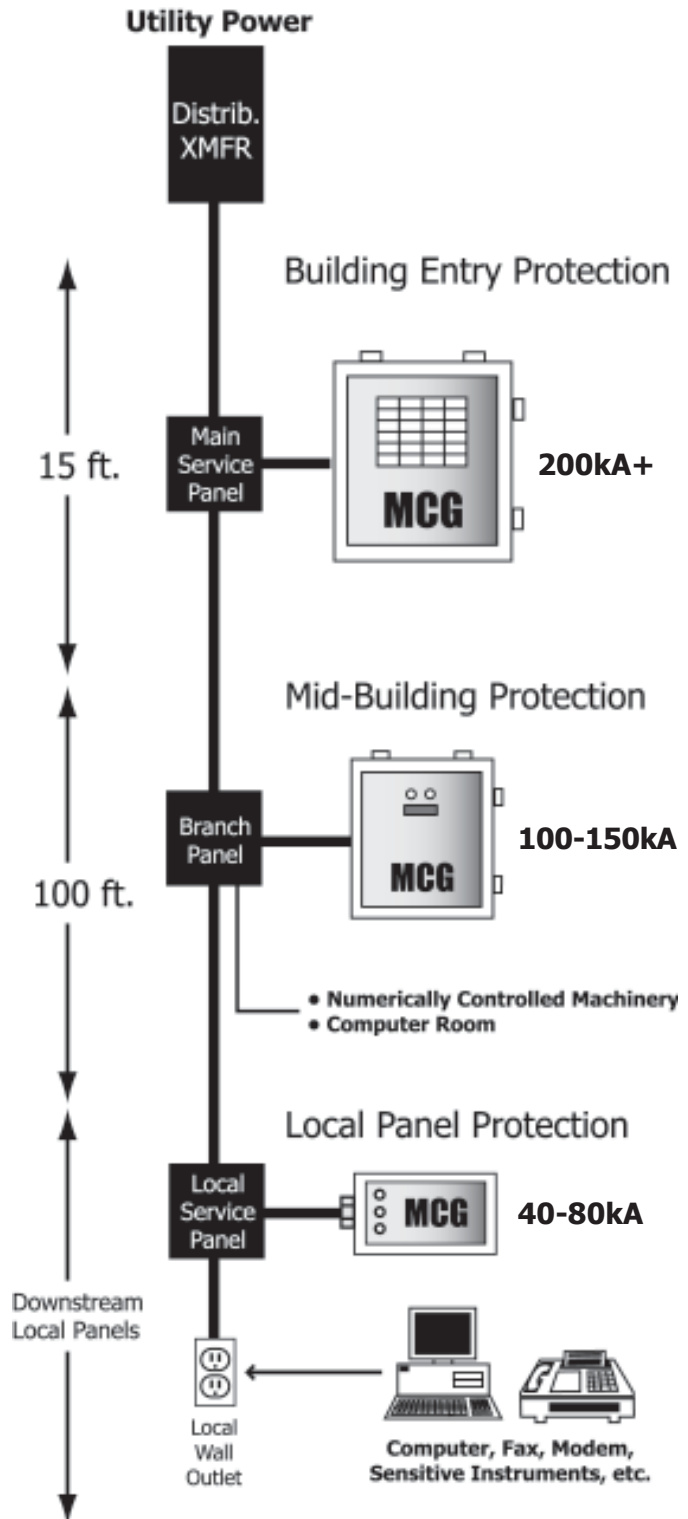

Product Comparison Sheet

Location

Building Entry Mid-Building Local Panel

Model

Rated Voltage (50/60/400Hz)

Service (phase, wye/delta, etc.)

MCOV

Performance Capability

Suppression Voltage: 3kA (8/20 μ s)

Suppression Voltage: 10kA (8/20 μ s)

Response Time

Energy (Joules) 8/20 μ s

UL 1449 Rated

Surge Life (8/20 μ s) @ I Peak

1 Event - NEMA LS-1 Rated

10,000 Events

Diagnostics

Transient Event Counter

Front Panel LED Indicators

Internal LED Indicators

Audible Alarm

Remote Alarm Capability

Safety

Fuse/MOV Coordination

Thermal Disconnect

Maintainability

Redundant Protection

Field Replaceable Modules and Fuses

Design Life (minimum)

Environmental

Operating Altitude

Operating Temperature

Mechanical

Enclosure Type (NEMA 4, 12)

Mounting Dimensions

Shipping Weight

Warranty

Unit Replacement

Replacement Modules & Fuses

MCG

Competitor

Comments

	MCG	Competitor	Comments
Model	_____	_____	_____
Rated Voltage (50/60/400Hz)	_____	_____	_____
Service (phase, wye/delta, etc.)	_____	_____	_____
MCOV	_____	_____	_____
Performance Capability			
Suppression Voltage: 3kA (8/20 μ s)	_____ V	_____	_____
Suppression Voltage: 10kA (8/20 μ s)	_____ V	_____	_____
Response Time	_____	_____	Not an issue
Energy (Joules) 8/20 μ s	_____	_____	_____
UL 1449 Rated	_____	_____	_____
Surge Life (8/20 μ s) @ I Peak			
1 Event - NEMA LS-1 Rated	_____ A	_____	Independent 3rd Party Tested
10,000 Events	_____ A	_____	_____
Diagnostics			
Transient Event Counter	_____ Yes	_____	_____
Front Panel LED Indicators	_____ Yes	_____	_____
Internal LED Indicators	_____ Yes	_____	_____
Audible Alarm	_____ Yes	_____	_____
Remote Alarm Capability	_____ Yes	_____	_____
Safety			
Fuse/MOV Coordination	_____	_____	_____
Thermal Disconnect	_____	_____	_____
Maintainability			
Redundant Protection	_____ Yes	_____	_____
Field Replaceable Modules and Fuses	_____ Yes	_____	_____
Design Life (minimum)	_____ 20 Years	_____	_____
Environmental			
Operating Altitude	_____ To 13,000 ft.	_____	_____
Operating Temperature	_____ -40°C to +70°C	_____	_____
Mechanical			
Enclosure Type (NEMA 4, 12)	_____	_____	_____
Mounting Dimensions	_____	_____	_____
Shipping Weight	_____	_____	_____
Warranty			
Unit Replacement	_____ 10 Years	_____	_____
Replacement Modules & Fuses	_____ Free for Life	_____	_____

Peak Current Capability- How Much Do You Need?

There is no simple answer. The number of lightning strikes occurring in the lower 48 United States ranges from 9 to 20 million strikes per year. What visually appears to be a single lightning bolt may be as many as 2 to 23 separate impulses, with different peak currents and wave shapes. The peak current (I_{peak}) is the most visible specification that a surge protector possesses. A surge protector size, located at the building entry, depends on geography, power line characteristics, and the economic risks one is willing to accept. Smaller surge protectors can be effectively employed at branch and local service panels. A five minute conversation with an MCG engineer may save you hours of time.

Lightning impulse currents come in many sizes-from small to very large.

Nature, every now and then, will produce a lightning impulse current in the 200 to 300kA range. However, the great majority of peak currents will occur from 5kA to 50kA. In the USA, Telephone Central Offices have successfully standardized on surge protectors with 20kA, 8/20 μ s impulse ratings. Where lightning will strike is unpredictable. Targets such as open fields, golf courses, mountains, tall buildings, towers, utility smoke stacks and very frequently, overhead power lines. The greatest threat, by far, to your equipment will come from lightning strikes to the power lines.

How does one define lightning?

Electrical engineers and physicists in the USA, Europe and Asia have defined amplitudes and waveforms to model the parameters of the lightning stroke. Factors considered were geography, the existing power systems and the experiences of people in the field. For a building entry, the IEC Standards Group settled on a 10/350 μ s waveform. Whereas the IEEE group (later ANSI C62.41) settled on 8/20 μ s current waveform. It appears the IEC group chose a very high energy waveform to protect against every conceivable lightning strike. The ANSI C62.41 Standards Group chose the lightning current waveforms that were most highly probable.

The USA approach: ANSI C62.41-1995:

The European Approach: IEC Standard 61643

What Standard does MCG use and why?

The ANSI C62.41 Standard has yielded excellent results for the sizing of surge protectors for use at the building entry and further within the building.

In addition, MCG employs the NEMA LS-1 Standard to certify its modules and building surge protectors (XT series) to meet a 200kA 8/20 μ s impulse successfully - without damage. These devices are tested by an independent third party testing organization.

The Proof is in the Pudding...

The number of MOV-based surge protectors now protecting sites in the US and around the world is very large, in the millions and growing. Protector failures have been infrequent and primarily due to inadequately regulated power systems.

Protection Guidelines – CBEMA Standards

Equipment Susceptibility to Transient Damage

Computer manufacturers do not acknowledge the sensitivity thresholds of their equipment. Their reluctance to be forthcoming is understandable since this information can and probably will be used by their competitors – to their detriment.

FIPS Guidelines

The Federal Information Processing Standards (FIPS) publication, “Guidelines on Electrical Power for Automatic Data Processing Installations” (FIPS Pub. DU294) includes a susceptibility profile (CBEMA curve) that is a design objective for computer hardware designers. The profile shows the relationship between maximum permissible suppressed voltage levels, system voltage and surge duration.

CBEMA Standard

The Computer and Business Equipment Manufacturers Association provided a performance profile for computer equipment known as the CBEMA curve. The curve illustrates the allowable peak transient voltage allowable when the AC line voltage and transient duration are considered.

CBEMA Curve

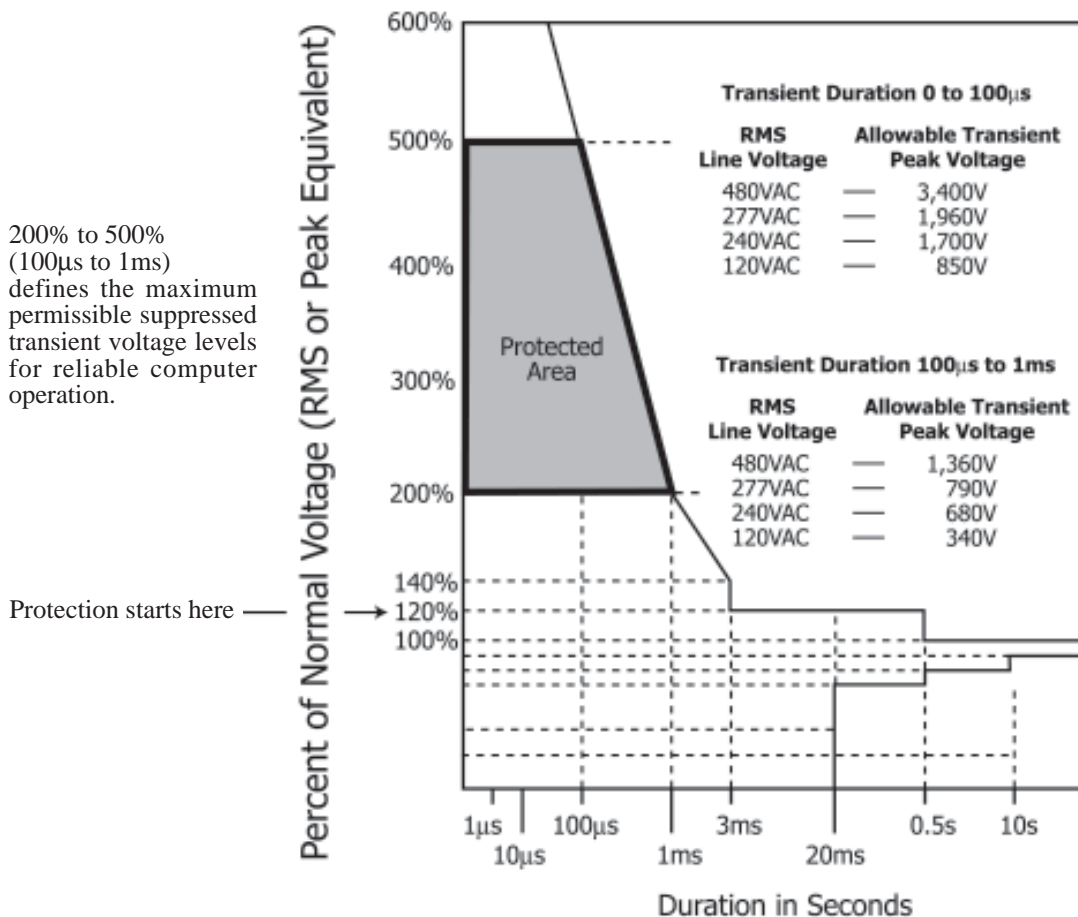

Are Published Surge Protector Clamp Levels - Realistic?

No! Surge protection manufacturers generally report only on the clamping capability of their surge protectors at the 6” (316cm) wiring connection cable to the protector. This is a UL 1449 requirement to standardize measurement comparison between surge protector manufacturers. No concern or mention is made of the very large voltage drops that will occur on the actual cabling between the surge protector and the service panel.

"Let-Through" Voltages

Can It Be Reduced?

Inductance of wiring presents a relatively high impedance path to ground. This can produce unwanted voltage drops which cause high "let-through" transient voltages to appear across sensitive equipment.

The diagram below illustrates the distribution of voltage drops and how the sum of the voltage drops appears across the load.

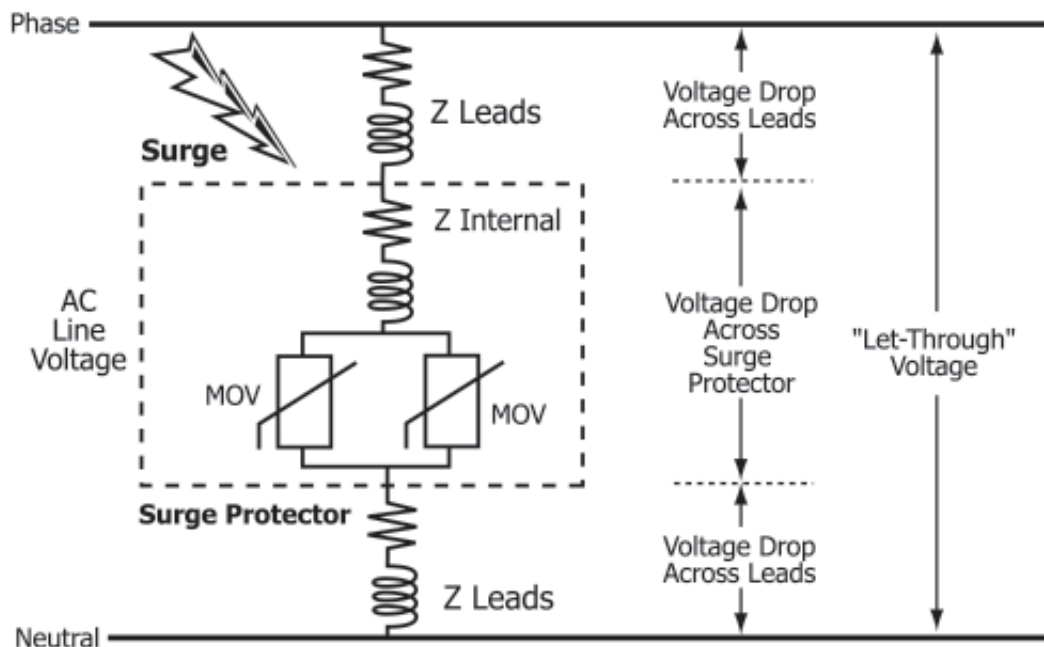

Undesirable inductance is present in the wiring from the AC power line to the protector as well as within the protector itself. Conventional protectors attempt to minimize inductive impedance by:

1. Using short and straight wiring - minimum slack, no extra turns, no loops.
2. Using very large diameter conductors for connection to the AC power line.
3. Dressing all leads tightly together, taping or tie-wrapping over their full length.

While these steps provide some benefits, they fall short of what can be accomplished. To truly minimize inductance, the Micro-Z approach to inductive control merits your attention.

Let-Through Voltage - Wire Size Considerations

It is desirable to limit the “let-through” voltage that appears across sensitive downstream equipment to as low a value as practical. Wire has two inherent characteristics that increase the “let-through” voltage of an installed surge protector. These parameters are its inductance in microhenries (μh) and its resistance, in ohms. It is desirable to keep the wiring inductance and resistance values low to reduce the inherent voltage drop that will occur along the wire. This might imply use of large diameter wires. Large wire sizes cost considerably more in material and labor to install.

Wire Inductance

The value of inductance increases with wire length and decreases as wire diameter increases. At a given length, the inductance of the #10 AWG wire and the 4/0 AWG cable is essentially equivalent, even though the circular mills differ by a 40/1 ratio.

A 4/0 AWG wire inductance is **1.0 μh for 40” length**. Area = 420,000 cm.

A #10 AWG wire inductance is **1.1 μh for 40” length**. Area = 10,380 cm.

Observation – the #10 AWG wire is inductively equivalent to 4/0 AWG cable.

Wire Resistance Considerations

The value of resistance increases with wire length and decreases as wire diameter increases. The voltage drops across the #10 AWG wire and 4/0 AWG wire are so low that they can be ignored.

A 4/0 AWG wire resistance is 0.049 milliohms/ft. A 10kA pulse will have a **0.5 Volt** drop per foot.

A #10 AWG wire resistance is 0.999 milliohms/ft. A 10kA pulse will have a **10 Volt** drop per foot.

Conclusion

The 4/0 AWG wire offers no significant advantage over the #10 AWG wire. For minimum “Let-Through” voltage, keep wire lengths as short as possible. Many of MCG’s protectors incorporate “Micro-Z”™ power cabling at no extra charge.

Micro-Z Concept for Better Performance

Micro-Z Concept combines the surge protector's patented internal design with an innovative external wiring configuration. The combination yields a significantly lower "let-through" voltage across the load. The Micro-Z approach is composed of three parts:

Micro-Z Cabling connected between the service panel and the surge protector

Micro-Z cabling forces a very efficient magnetic field cancellation within the cable. This results in a correspondingly low inductive voltage drop along the cable that is 50% lower than achieved with conventional wiring.

Micro-Z Construction approach (U.S. Patent No. 5, 303, 116)

Micro-Z construction lowers the internal impedance of the surge protector by designing the physical layout to create cancelling magnetic fields. This results in lower voltage drops across the surge protector's internal wiring.

Micro-Z Power Buss

Micro-Z Power Buss provides massive solid copper busses for extraordinary I peak current handling capability within the surge protector.

Conclusion

The Micro-Z concept significantly improves the surge current path to ground resulting in considerably lower transient voltage stress to sensitive downstream equipment.

Cross section of cable showing location of each conductor

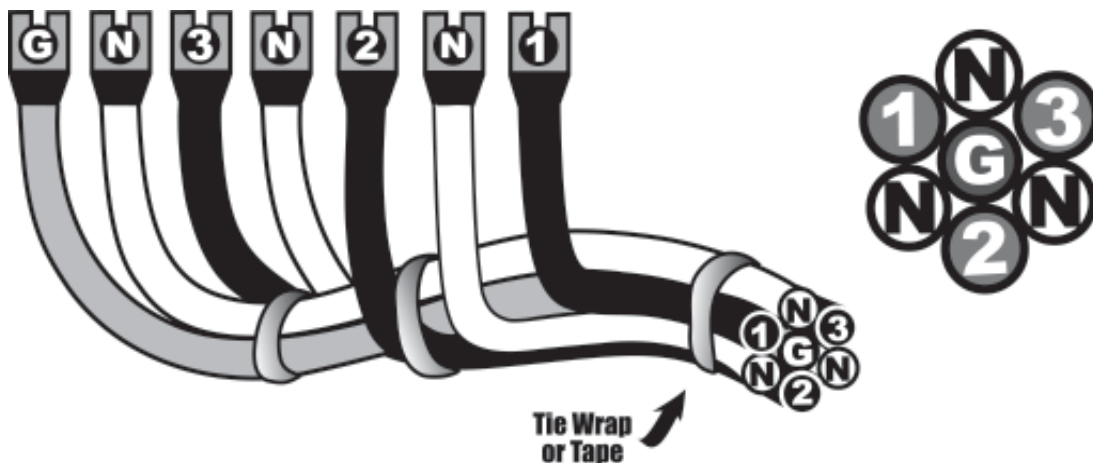

Most MCG surge protectors come equipped with Micro-Z cable already installed at no extra charge.

Voltage Drops Along Power Cabling

Cable Voltage Drop - Micro-Z vs. #6 AWG

Test Conditions:

Velonex Pulse Generator delivered a Standard ANSI C62.41 waveform (6kv/3kA, 8/20 μ s) into a 12 foot cable pair, consisting of two #6 AWG power cables, tightly taped along its full length.

Measurements:

Voltage drop measurements were made at 1 foot intervals along the cable length.

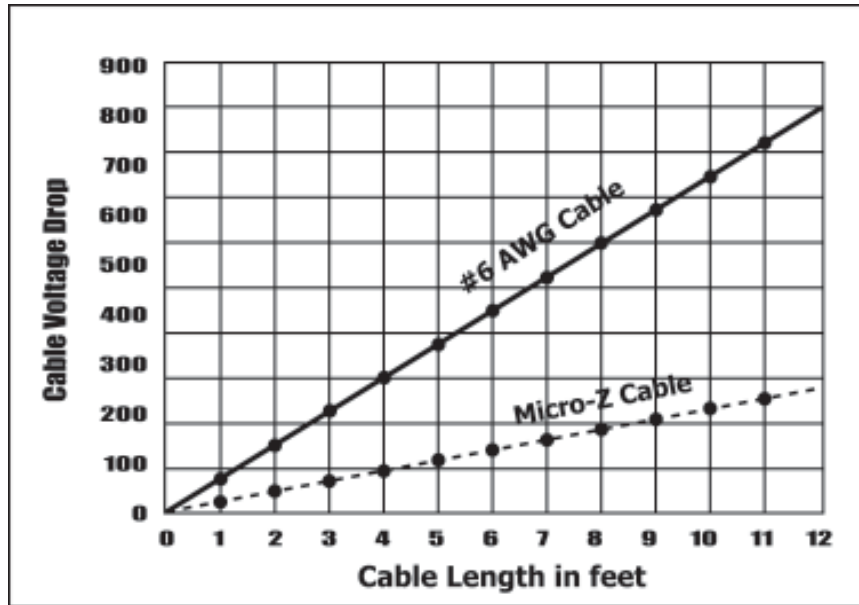

Micro-Z™ Cable

Axial power cabling configuration from the protector to the service panel forces magnetic field cancellation within the cable. This results in a correspondingly low "inductive" voltage drop along the cable that is up to 67% lower than conventional cabling approaches.

Observation

Your sensitive equipment will be exposed to a peak transient voltage which is the sum of the surge protector's "Clamp Voltage" + the cable voltage drop, which is a function of its length.

Example

A surge protector designed for use on 120 VAC Service, will limit a 6kv/3kA (8/20 μ s) transient to a clamp voltage of 464V at its terminals,

...with 3ft. of #6 AWG cable, equipment exposure totals: 464V + 220V = 684V

...with 3ft. of Micro-Z™ cable, equipment exposure totals: 464V + 70V = only 534V

Using 9ft. of Micro-Z™ cable, equipment exposure totals are: 464V + 207V = 671V, or about the same as three feet of #6 AWG cable.

Conclusion

Use of Micro-Z cable reduces "let-through" voltage by 150 volts!

High AC Line Voltage: Requires Several Strategies

A high-line condition is a long term, abnormally high AC line voltage whose amplitude is higher than the nominal AC line voltage by 10%. MOVs are damaged when the AC line voltage exceeds the surge protector's maximum continuous operating voltage (MCOV), which is typically 15% above the nominal AC line voltage.

A surge protector has competing requirements that must be met.

Sensitive equipment requires a low clamping voltage on the AC power line.

The sensitive equipment must be shielded from short duration (μ s) high voltage transients that appear on the AC power lines and cause internal damage to semiconductors, microprocessors, etc.

The surge protector needs a higher clamping voltage if it is to survive.

The danger to a surge protector occurs when its MOV's attempt to clamp the peak of the abnormally high AC line voltage. The MOV's will start overheating and the AC line current, producing the heating, will be well below the fuse's operating current. The heating of the MOV's will be prolonged, will produce smoke, sooty deposits and will damage itself and neighboring components. Major damage to the protector will occur.

The Solutions

1. Use higher voltage MOVs that are much less susceptible to AC line overvoltages.
2. Use a Micro-Z cable connection from the surge protector to the AC power panel to keep the inherent cable voltage drop to a minimum. The lower voltage drop in the Micro-Z cable will easily compensate for the higher voltage MOVs.
3. Use a protector that has internal thermal disconnects that remove any MOVs that are overheating.

Caution

A lower clamping voltage can be achieved by using lower voltage rated MOVs. However, the very small reduction in the clamping voltage is obtained at the greatly increased risk of a surge protector failure.

Fuse and Thermal Disconnect Considerations

Fuse KAIC rating

Surge protectors are connected in shunt with the AC power lines. On occasion, a severe lightning surge can cause an MOV element to fail as a short circuit, thereby requiring its series fuse to open and remove the shorted MOV from the AC power line. The fuse must be capable of interrupting the AC power line short circuit fault current. The available short circuit rms current is limited by the impedance of the distribution transformer and its connecting cables. A fuse with a 200,000 Ampere Interrupt Current rating (KAIC) has proven to be universally appropriate for almost all sites.

KAIC ratings should not be confused with a surge protectors I peak handling ability.

- KAIC ratings apply only to 50/60 Hertz AC power line short circuit currents.
- I peak applies to large amplitude, microsecond impulses - such as lightning.

Fuse / MOV Coordination

It is essential that a surge protector's fuses withstand short-duration, high-amplitude transient currents without opening in the course of normal suppression activities. Proper fuse / MOV coordination further requires that a fuse open rapidly at a point just prior the MOV failure point. For example, a 40mm MOV has an I peak rating of 40kA for an 8/20 μ s wave form. Actually it is closer to a 50kA, 8/20 μ s rating. It is important that the fuse be capable of opening rapidly when the 40kA rating is exceeded. Fuse characteristics vary widely and not all fuses are suitable for coordination activities.

Thermal Disconnect Capabilities

On AC power lines that are not well regulated, it occasionally happens that the AC power line voltage will increase suddenly by 30 to 50%. This power line overvoltage will cause the surge protector's MOV's to attempt to limit the sine wave peak voltage by diverting AC line current through the MOV's to neutral. The MOV's will rapidly overheat, become a short circuit, rupture, spew smoke, soot and burn up.

A thermal disconnect is a device, mounted on or near each MOV element, that responds to excessive MOV heating, by mechanically disconnecting the MOV from the power line. Each MOV should be individually protected and the thermal disconnect mechanism should not be sensitive to physical orientation.

Redundancy: True vs. False Redundancy

Multiple protection pathways to ground are critical. A lightning strike often consists of multiple current strokes to the power lines, or earth. As many as two to twenty strokes can occur in a single lightning event.

To provide proper system protection, the building entry surge protector needs to have at least two, and preferably several, independently fused, parallel protection sections per phase. The failure of a single protection section in a surge protector, in a severe lightning storm for example, would then not be catastrophic. System protection would continue to be maintained.

It is recommended that this redundant concept be continued at the mid-building/branch level, while the local service panel protectors can safely employ single protection approaches.

Redundant “Backup” Protection Without Adequate Fusing is a Weak Link. By matching a fuse’s current rating with the MOV’s peak current rating solid reliable protection, without nuisance fuse blowing, can be achieved.

1) False Redundancy

Multiple Current Paths... Yes

Redundant Protection... NO!

If F1 fails:

Suppression capability is completely eliminated.

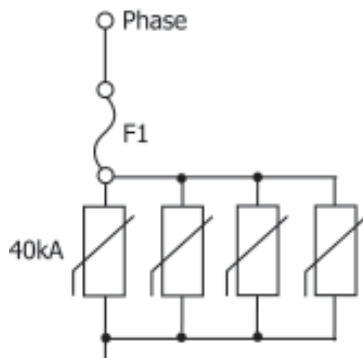

2) True Redundancy

Multiple Current Paths... Yes

Redundant.....Yes - 4x

If F1 fails:

Suppression capability is reduced to 75% of normal.

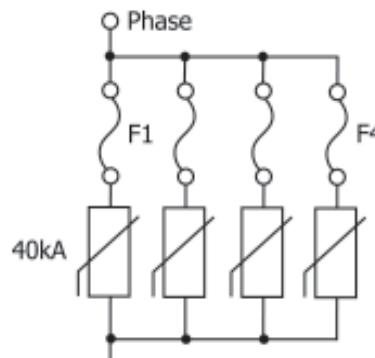

Conclusion:

True redundancy requires multiple fuses and multiple MOV’s and effective fuse/MOV coordination.

Modular Design Considerations & Problems

Modular construction is a packaging approach designed to aid repair and maintenance of a surge protector when installed at a site. Closely associated with modular design is the need to pinpoint the defective module(s).

Locating the Defective Module

Ordinarily, a surge protector will operate a front panel LED when an internal failure occurs. Well designed protectors will indicate by LED (or other means) the defective module in question

Protectors Employing Modular Construction are Field Repairable

When identified, the defective modules can be quickly unplugged or unbolted. Typically, removable modules can be replaced in 15 to 30 minutes.

Non-modular Protectors have Several Serious Limitations

Should a failure be indicated, the unit or a major portion of it must be removed, replaced by a

1. substitute, or sent to the factory for repair. These units are not field repairable since the critical protection elements are encased in a sand/epoxy mixture.

The use of low cost MOVs creates a very large monitoring problem. Should each 20mm

2. MOV/fuse combination be monitored? This greatly increases the cost of the monitoring by a factor of five times that of larger 40mm MOVs. An alternate approach is to monitor groups of MOV/fuse combinations. This reduces the monitoring cost and complexity but creates another serious problem.

When exposed to transient currents, random MOVs will fail - blowing its series fuse, but not

3. necessarily indicating a reduced protection capability. Random failures among the various groups can lead to greatly reduced surge protection capability - **without an alarm being given.**

When the protection capability is needed - it may not be there!

Monitoring and Diagnostics

Why Is Monitoring Needed?

Surge protectors limit transient voltages appearing on the AC power line to less than the susceptibility levels of sensitive equipment. It is important to know **immediately** whenever a surge protector's capability has diminished, either through long-term degradation in a "standby" mode or while involved in active suppression activity.

Factors Affecting Surge Protector Capability:

Long-Term Degradation

In spite of undocumented accounts to the contrary, extensive reliability data on MOV's indicate that there is no meaningful long-term degradation of MOV's in standby operation. See Harris "1995 Transient Voltage Suppression Devices" handbook, pages 5-10 to 5-20.

Active Service Failure

"Varistors initially fail in a short-circuit mode when subjected to surges beyond their peak current/energy ratings. They also short-circuit when operated at steady-state AC line voltages well beyond their ratings..." Harris handbook, on page 6-6. A surge protector correctly rated for the application will operate without interruption for 20 or more years.

Current Monitoring Practice

Most protectors provide a fuse in series with the MOV to disconnect it from the power line should the MOV fail. By monitoring the fuse opening, the protection system signals a diminishing of protection capability. To handle very large surge currents, it is standard practice to parallel MOV's with each MOV having a series fuse. It is at this point that there is a divergence in protection philosophy.

The Conservative Approach

Requires that all of the fuse/MOV sections be monitored and that the failure of any one section will cause an internal, immediate fault indication by LED, audible beep, etc. to occur. In addition, a front panel LED should indicate reduced protection. Some surge protectors will indicate the percentage of protection capability remaining for each phase. This approach is 100% effective. It signals a malfunction immediately with only a slight additional cost, when compared with a less comprehensive monitoring approach.

The Minimum Approach – A Disaster Waiting To Happen!

The minimum approach observes only a few, and often only one, fuse/MOV circuit combination and signals the fall off in protection capability when this solitary fuse opens. Unfortunately, some manufacturers continue to use this approach to monitor protection integrity.

The minimum approach has a serious flaw - the unmonitored fuses may open and there will be very substantial erosion of protection capability without anyone's knowledge! At some future time, a large transient surge will appear and the final fuse will open. Downstream sensitive equipment will be exposed to catastrophic damage because of an inadequate number of MOVs to handle a large surge current.

Conclusions

Each fuse/MOV circuit must be monitored to avoid hidden protection erosion.

Front panel indicators are mandatory to signal internal problems.

Employ internal LED's to pinpoint the defective module(s) and fuses.

Provide relay contact closures to provide remote signal capability.

Life Expectancy

Product Durability

It is useful to know the relative durability of surge protectors made by different manufacturers.

Joule Ratings Count!

The joule rating of a MOV-based protector is a direct measure of its capability to handle a large number of standardized (8/20us) transient impulses. The relative life expectancy of competitive MOV-based protectors can be easily assessed by comparing their joule ratings. In any comparison, variations in joule capability by +/- 10% are not considered to be significant. Surge Protector joule rating must be compared using the same 8/20 microsecond waveform and the same MOV technology.

The Comparison to Remember

An easy rule to remember is that if one protector has twice the joule rating of another, then its life expectancy is ten times longer because of the nonlinear characteristics of MOVs.

Environmental Factors

Altitude

Operation at altitudes up to 13,000 ft. (4000m) is desirable since it covers all but the most extreme sites. High altitude surge protector designs require greater conductor spacing providing an additional margin of safety.

Temperature

Operating temperatures of -40°C to +55°C will cover most applications. It is desirable that components be rated to +85°C.

Moisture

Protector units should operate reliably in 95% humidity, non-condensing.

NEMA Enclosures

NEMA 4

- General purpose
- Indoor/outdoor locations
- Weather and water resistant
- 14 gauge steel
- Stainless steel hardware

NEMA 4X

- Special duty
- Outdoor/corrosive/wet locations
- Weather, water and corrosion resistant
- 14 gauge steel
- Corrosion steel hardware

NEMA 12

- Light Duty
- Indoor locations
- Dust and dirt resistant
- Drip-proof
- 14 gauge steel
- Standard hardware

Installation Q & A Tips

Should the Surge Protector be on line or load side of a service panel?

The surge protector, when installed on the line side of a service panel, will continuously protect all the loads connected to the service panel. If any of the loads are removed by circuit breaker operation, the remaining loads will continue to be protected. The line side surge protector requires a dedicated fuse and/or circuit breaker for safety reasons. For this reason, in most applications, the surge protector is installed on the load side of the service panel.

Can we install the Surge Protector on the load side of a service panel?

Yes! If the surge protector is the only device connected to the load side of that particular circuit breaker, then it is effectively connected to the line side through the circuit breaker itself. Opening this circuit breaker will allow the surge protector to be worked on without dangerous potentials being present within the surge protector. **This is the most common and economical way of connecting a surge protector to the service panel.**

How close should the surge protector be mounted to the service panel?

As close as physically possible! The surge protector should be installed immediately alongside the service panel. Any saved inches can provide a considerable improvement in the surge protector's transient suppression results.

How important is the connecting cable?

The connecting cable is very important. Sensitive downstream equipment must not be exposed to transient voltage in excess of the CBEMA recommended levels. Micro-Z cabling has a much lower "let-through" voltage drop than conventional wiring. Many of MCG's surge protectors are provided with Micro-Z cabling already installed.

What wire size should be used for wiring up the surge protector?

Contrary to some opinions, the wire diameter is relatively unimportant, but the **shortness of the wiring connection to the service panel is very important.** See *Wire Size Considerations* for more detail.

What should the amperage rating of the circuit breaker be?

For # 8 AWG stranded wire... use a 50 Amp circuit breaker

For # 10 AWG stranded wire ... use a 30 Amp circuit breaker

For # 12 AWG stranded wire... use a 20 Amp circuit breaker

Wiring Diagrams - Phase Connections

Single Phase, 2 Wire + Ground

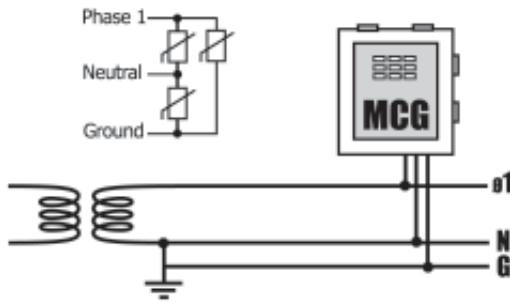

Single Phase, 3 Wire + Ground

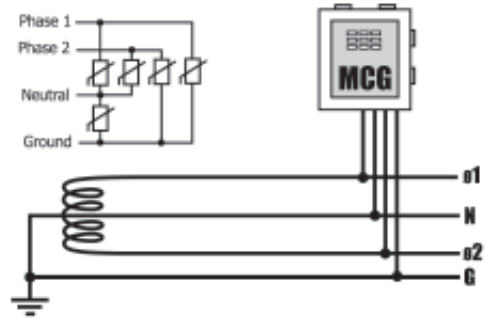

High Leg Delta, 4 Wire + Ground

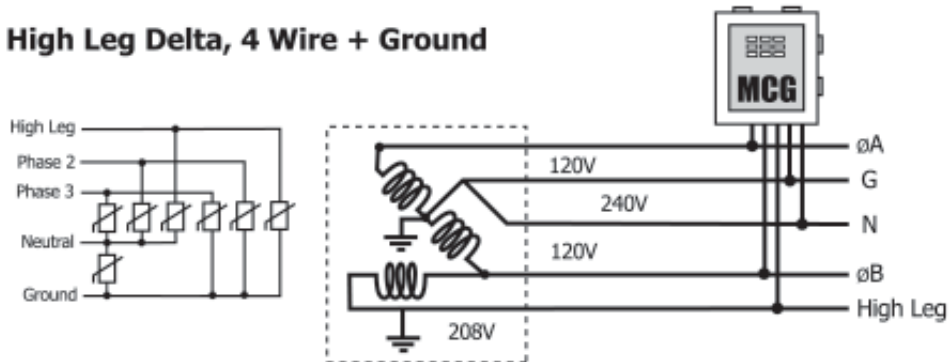

Three Phase, Wye, 4 Wire + Ground

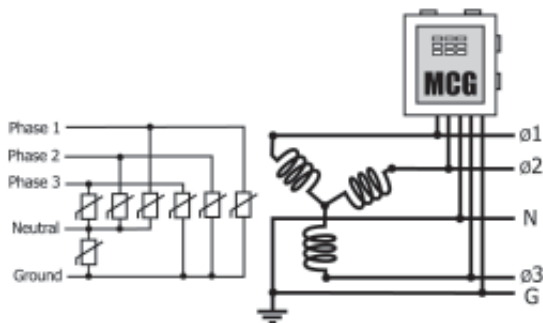

Three Phase, Delta, 3 Wire + Ground

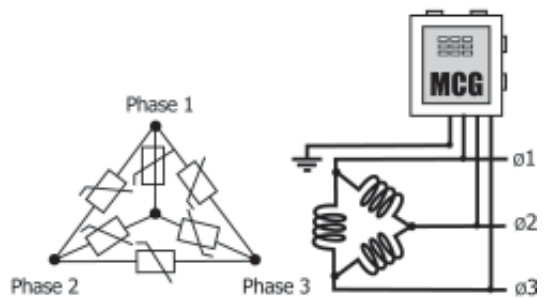

Safety Disconnect Switch Considerations

On occasion, it may be necessary to provide maintenance or repair to a surge protector that has experienced damage in the performance of its protection function. This will require disconnecting the AC line voltages from the surge protector equipment. There are two ways to do this.

Circuit Breaker Approach

This approach relies on the operation of a circuit breaker located at the service panel to remove AC line voltage from the surge protector. It has the dual advantage that no additional wire length (inductance) is added in series with the surge protector and the certainty that harmful AC line voltages are not present within the enclosure. The cost of the external circuit breaker is minimal.

Front Panel Disconnect Switch

Manufacturers will provide, at additional cost, an internal disconnect switch, a portion of which pokes through the front panel to permit the AC line voltage to be disconnected at the surge protector front panel. Additional internal wiring (inductive) is required to permit the disconnect switch to be inserted between the suppressor assembly and the AC line voltage connections. In some cases, the disconnect switch wiring may not be completely shielded from human touch. This could be hazardous to those servicing the equipment.

The Bottom Line

The marginal improvement in accessibility to the interior of a surge protector may not warrant the additional cost. This is especially true, if the protector is ruggedly built and seldom, if ever, has need for service. Consider also, that any additional wiring will increase the series inductance and correspondingly will increase the “let-through” voltage that the downstream sensitive equipment will experience.

Ground - The Single Point Concept

There are many grounding requirements that must be addressed to ensure electrical circuits will perform as intended. In terms of protecting your equipment from transient electrical anomalies, a good ground is important. But it is *vital* that all grounds in a facility be connected together and brought to a single ground point (driven rod/cold water pipe) at the service entrance.

Separate grounds permit differences in ground potential within a facility. The result is that sensitive equipment may be exposed to differential voltages that will cause damage – even with surge protectors installed. If the grounding system of a facility is not known, protection can be assured by locating the protector at the load and grounding it to the chassis of the equipment.

Sine Wave Tracking & EMI/RFI Filtering

Not Always Credible

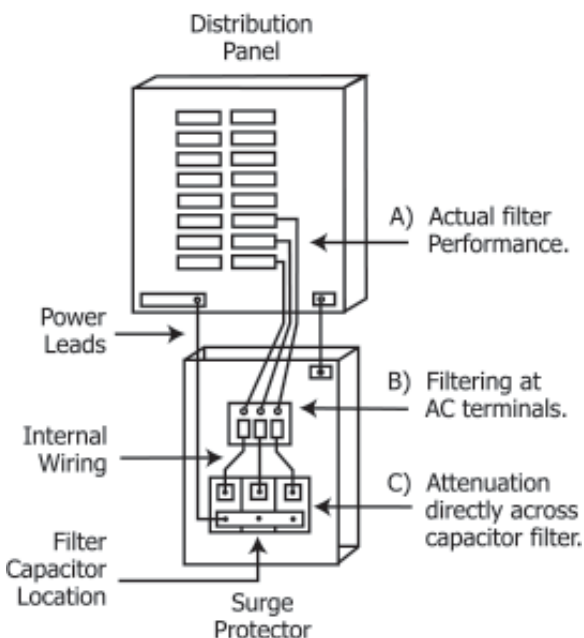

Fig. 1 Location of frequency measurements.

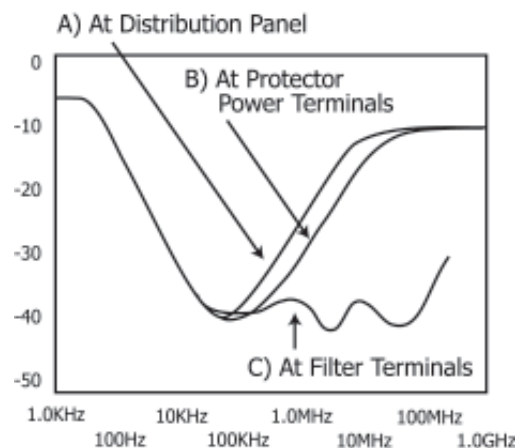

Fig. 2 Attenuation (db) vs. frequency at different locations

Are sine wave tracking and EMI/RFI filtering the same thing?

Yes. Sine wave tracking and/or EMI/RFI filtering is a marketing approach that adds a high frequency filtering capability to a surge protector's normal function of limiting transient surge voltages to safe levels. This filtering is achieved by shunting the phase to neutral AC power line terminals with an inexpensive polypropylene capacitor. Filtering capability of a high quality capacitor is substantial when measured **directly** at the capacitor's terminals, but falls off sharply as the measurements are made at the AC service panel, as is shown in the chart below.

Location	100kHz	1MHz	10MHz	100MHz	Comments
C	40	39	37	36	Published Performance - at Filter Module
B	40	28	11	6	Attenuation at the SPD Power Terminals
A	39	20	7	6	Service Panel - Actual Performance

Observation

The inevitable wiring connections between the "filter capacitors" within the surge protector and the AC power lines will introduce unavoidable impedance between the power lines and the filtering elements. This wiring impedance will sharply degrade the filtering performance above 1 megahertz.

Conclusion: If the filtering does not show up at the service panel - it doesn't exist!

Hybrid Protection Circuitry

Hybrid Surge Protection is the blending together of two (or more) technical approaches to achieve a new result that is unachievable by either technology by itself. Several hybrid approaches are being promoted in the marketplace.

Selenium Cells + MOV's Approach

In this approach, the selenium cells are designed to start conducting at some point just above the peak of the sine wave voltage. Relatively small amplitude surge currents are diverted by the selenium away from the load.

As the surge currents increase in magnitude, the turn-on threshold of the MOV's will be exceeded and almost all future increases in surge current will be diverted by the MOV protector elements. The rapidly rising selenium clamping voltage is due to its inherently small nonlinear exponent. The MOV's will now be the major determinant of the effective clamping voltage for the higher surge currents above 1000 Amps.

Conclusion

For major transient events, 1,000 Amps and upward, the health of the protected system rests almost solely on the performance of the MOV devices. Selenium technology seems to be a marketing tool rather than a genuine performance improvement.

The MOV + SAD Approach

In this approach, the Silicon Avalanche Diodes (SAD's) are designed (as in the Selenium/MOV approach) to start conducting at some point just above the peak of the sine wave voltage. Relatively small amplitude transient surge currents are diverted away from the load by the SADs.

Because of the SAD's very limited current handling ability, it takes many silicon avalanche diodes, in a series parallel matrix, to equal the current handling of one-40 mm MOV on the 120VAC line. Clearly, an inefficient and very expensive proposition!

Consequently, the typical SAD module employed, per phase, contains 250 diodes in a matrix configuration having a peak current rating of 1000 Amps, for a 10/1000 microsecond waveform. This low energy handling module gives the SAD/MOV approach the initial appearance of providing a lower clamp voltage. **When the transient currents become large – the MOVs do all the heavy lifting!**

Conclusion

For major transient events, 1,000 Amps and upward, the health of the protected system rests, almost entirely, on the performance of the MOV devices. The avalanche technology has to be sheltered – it can't handle the abuse alone.

Test Equipment - Useful or Illusionary?

Some manufacturers choose to sell costly external testing instrumentation to periodically measure the health of their surge protector.

The test equipment benchmarks the surge protector's initial factory clamping voltage levels and then it uses these as a guideline for periodic maintenance checkups. One manufacturer offers the test equipment for \$2000, an offer well in excess of the cost of a new surge protector.

At best, this approach requires a wait of one to six months for the "Test Equipment" to "assess" the health of the surge protector, as opposed to on-board, continuous monitoring systems.

At worst, transient damage can occur one day after a test day and not be indicated until the next measurement interval. As a practical matter, the annoying periodic maintenance time required will inevitably lead to this costly piece of equipment falling into disuse.

A more serious problem exists using this approach.

The test equipment's creation of a test pulse typically of 3 to 5 Amps means that the paralleled protection elements (MOV's, Selenium Cells, Avalanche Diodes and others) will be sharing this test current with the lowest clamping protection element shunting up to 100% of the test current. **This is not an adequate test!**

In hybrid protection approaches, MOV/Selenium or MOV/Avalanche Diodes, a small test current will be clamped by the Selenium cells, or the Avalanche Diodes exclusively since these suppression elements were deliberately chosen to **turn on** first. **The MOV elements may not be tested at all!**

Conclusion

The important high energy handling MOV's, in hybrid configurations, **MAY NOT PROPERLY BE TESTED**. Use of external test equipment promotes a false sense of security and unnecessary expense. On-board, continuous monitoring of the surge protector's health is much more effective and less costly.

Open Technology – Why the Secrecy?

What is "Open Technology"?

It is our belief that the customer needs to know fully about the product characteristics and expects clear, concise documentation on the device being considered.

Are there "trade secrets"?

No, not really. After more than 34 years of ongoing technological investigation into the manufacture of surge suppressors, which involved the occasional dissecting of products for detailed inspection, there were seldom any surprises.

What about Patents?

MCG Electronics, Inc. has two United States Patents that relate to surge protection.

U.S. Patent No.	Inventor/Assigned To	Description
5,303,116	Glenn Grotz MCG Electronics, Inc.	Describes internal surge protector construction to reduce inductive voltage drops by creating cancelling magnetic field.
6,211,770 B1	Michael Coyle MCG Electronics, Inc.	Describes methods of combining fusing and MOV construction.

Why the secrecy?

Surge protectors are constructed using available technology. An appearance of uniqueness can be created if one is careful to restrict information about its protection system. Claims of proprietary technology warrant skepticism.

The Bottom Line

The voltage suppression technologies involved are well known and understood. It is how a manufacturer addresses the fundamentals that separates a good product from a weak or vulnerable one.

Advertising Terms - Exotic Uses of the English Language

This section shows the creative heights to which relatively uncomplicated concepts have been elevated. While attempting to shed some light, we do not claim to provide a comprehensive description of any of these concepts. We leave the full explanation to the people who created them.

Lattice Matrix SAD:

Silicon Avalanche Diodes connected in a series-parallel configuration.

EMI/RFI Filter System:

In “hard-wired” surge protectors, the simplest kinds of high frequency filters typically employing a few capacitor(s) to shunt the AC Power Line. The use of capacitors and long wiring in these applications greatly limits their ability to effectively bypass high-frequency signals.

Sine Tracking:

A variety of terms that use various combinations of the words *Sine*, *Wave* and *Tracking*. Actually, Sine Tracking is simply one or more capacitors shunting the AC power line to attenuate high frequencies that appear on the power lines. See sections on *EMI/RFI Filtering and Sine Wave Tracking*.

“Unique” Chemical Compound:

An epoxy compound used to encapsulate modules. Frequently units are encapsulated to prevent customers from knowing what is inside. Claims are made that MOV heating is absorbed by the epoxy, thus allowing the MOV to operate at a reduced temperature. In reality, the epoxy encapsulated MOVs will absorb the transient-generated heat long before any heat conduction can occur.

99% Silver Links:

A fuse by any other name is still a fuse.

Hybrid Protection:

Combining two or more surge protection technologies to provide “enhanced” performance. See *Hybrid Protection Approaches* discussion for more details.

Silicon Arrestor:

A conventional spark gap buried in sand (silicon).

Standards – Industry and Safety

ANSI C62.41-1991— IEEE Recommended Practice on Surge Voltages in Low Voltage AC Power Circuits

Describes the AC power line environment in a simplified form and establishes a set of representative surge waveforms. It tends to simulate the dynamics of the AC power line environment.

ANSI C62.45-1992 — Guide to Surge Testing for Equipment Connected to AC Power Circuits

Provides technical guidance for use of surge testing equipment in the evaluation of a surge protector. The document calls attention to the important safety aspects of surge testing. This standard does not confer qualification, it merely tests the protector.

NEMA LS 1 — 1992 Low Voltage Surge Protective Devices

Establishes a guide for manufacturers of TVSS's to encourage uniformity of specifications. NEMA LS-1 testing by a third party insures that a manufacturer's product meets its published peak current specifications.

UL 1283, 3rd Ed. — Electromagnetic Interference Filters

This standard reviews the construction and suitability of the EMI filter for safe use on 600VAC (or less) power lines.

It does not test the EMI filters noise attenuation vs. frequency data.

Some manufacturers are positioning their reputed filter attenuation figures to be adjacent to the UL 1283 discussions and thus infer a UL 1283 endorsement. See section on *EMI/RFI Filtering*.

UL 1283 is only a safety specification, not a performance standard.

UL 1414, 4th Ed. — Across the Line...Capacitors

This standard evaluates across-the-line capacitors for safety only when used in L-N and L-G modes on surge protectors. This specification does **not** evaluate any filtering characteristics that may occur as a result of their use.

UL 1414 4th Ed. is only a safety standard.

UL 1449, 2nd Ed. — UL Standard for Safety for Transient Voltage Surge Suppressors

This standard evaluates the safety aspects of a surge protector connected across the AC power line and measures the Suppressed Voltage Rating. The SVR rating is printed on the product label. A surge protector might have 450 Volts clamping level but will receive a UL (SVR) rating of 500 Volts. The SVR rating is a group category rating - not necessarily the actual clamp voltage rating.

ANSI C62.41-1991 Standard

Protection Categories

Cat. C

Cat. B

Cat. A

Service Entrance

Category	1.2/50 μ s	8/20 μ s
C1	6kV	3kA
C2	10kV	5kA
C3	20kV	10kA



Impulse



Impulse

—

—

Mid Building

Category	1.2/50 μ s	8/20 μ s	0.5 μ s	100kHz
B1	2kV	1kA	170A	2kV
B2	4kV	2kA	330A	4kV
B3	6kV	3kA	500A	6kV

—



Impulse



Impulse

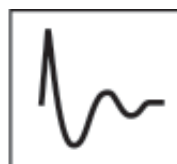

Ringwave

—

Local Panel

Category	0.5 μ s	100kHz
A1	2kV	70A
A2	4kV	130A
A3	6kV	200A

—

—

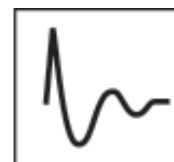

Ringwave

Glossary of Technical Terms

Clamp Voltage

The clamp voltage is the measured maximum voltage appearing across a surge protector when a standard waveform (simulating a lightning transient) is applied to the surge protector.

Some manufacturers, to gain a slightly lower clamping voltage, will narrow the headroom spread by using lower voltage MOVs - this greatly increases the likelihood of protector failure in the field. **All in all, a big risk for a very small, if any, performance improvement.**

Headroom

Headroom is the difference in voltage between the peak of the sine wave and a higher threshold voltage level where the MOV starts to turn on. If the headroom spread is too small, the MOV's may conduct more frequently resulting in a shorter MOV life. Headroom margins of 15% and greater address this issue with virtually no effect on suppressor performance. In some areas, power line fluctuations can exceed 15%. Prudent design requires higher clamp voltage MOVs in these situations.

Let-Through Voltage

Sensitive equipment located downstream on the AC power lines will be exposed to the clamp voltage of the surge protector while it is diverting the transient to ground. It is always desirable to minimize the "let-through" voltage

MCOV

MCOV is the Maximum Continuous Operating Voltage that can be applied to the surge protector without damaging it. Utilities generally maintain the line voltages to tight tolerances. If the line voltage rises above the specified MCOV for a sustained period of time, the surge protector's MOV's will begin to conduct and protector failure will eventually occur unless certain measures are taken.

Rated Voltage

The rated protector voltage corresponds to the nominal line voltage supplied by the utility. The protector type must conform to the utilities service configuration, i.e., single or three phase, delta or wye, etc.

Threshold Voltage

Threshold voltage is the turn on point at which a surge protector starts to conduct 1ma of current. By itself, this is an incomplete indicator of performance.

Warranty

MCG offers a 10-year "No-Nonsense" Warranty

Should the basic surge protector assembly suffer damage while in service, MCG will replace the unit immediately, without charge.

MCG provides free replacement modules and fuses.

Should any module or fuse need to be replaced in a surge protector, MCG will replace them without charge, beyond the 10-year warranty period.

Quality - ISO 9001 Certified

MCG will engineer, manufacture, and deliver surge protection equipment that will meet customers expectations at a fair and reasonable price, and back it up with our "No-Nonsense" warranty.

Index	Page
Advertising Terms	28
Component Life -MOV	19
Construction, Micro-Z Cabling vs. Conventional	14
Current, 1ma threshold	9
Distribution Transformer	9
Economic Justification for Surge Protection	6
EMI/RFI Filtering	24
Enclosures, NEMA 4, 4x, 12	20
Environment - Altitude, Moisture, Temperature	20
Fuse -MOV Coordination, KAIC Rating	16
Ground - The Single Point Concept	23
Headroom	31
Hybrid Protection Approaches - MOV/SAD, MOV-Selenium	25
I Peak	9, 16
I/O Port Failures - Data Line Protection	3
Impedance, Internal/External Wiring	11
Inductance	11
Installation Notes	21
Joule Rating	20
KAIC Rating	16
Let-Through Voltage	12
Lifetime Rating	20
Lightning - Multiple Strikes, Utility Lines, Etc.	5
Micro-Z Concept	13
Modular Construction	18
Monitoring - LED's, Beepers, Etc.	19
MOV Life	19
Multiple Pathways - Fuse/MOV Combinations	17
NEMA LS-1	9
Open Technology - Patents, Trade Secrets	27
Product Comparison Sheet	8
Protection Categories - ANSI, UL	29
Protector - Requirements or Proper Coordination	16
Redundancy, False Redundancy	17
Response Time - Transients	4
Service Panels - Main/Distribution, Branch, Local	7
Sine Wave Tracking	24
Standards - ANSI, IEC, NEMA, UL	29
Standards - CBEMA	10
Surge Protection Device (SPD) - Types of	25
Test Equipment, Usefulness of	26
Voltage - "Let Through"	12
Voltage - Rated, MCOV, Threshold, Clamp, Let-Through	31
Warranty	31
Waveforms	30
Wire Size Considerations	12